

AZDEC LIMITED

SPECIFICATION

INFRA-COM™ SYSTEM

**Infra Red
Two Way Mobile Digital Voice Systems**

CONTENTS

1. SYSTEM DESCRIPTION	3
2. INTERFACING	5
3. DOCUMENTATION	7
4. DETAILED SPECIFICATION	8
5. NATO STOCK NUMBER / AZDEC PART NUMBER CROSS REFERENCE	21

1. SYSTEM DESCRIPTION

- 1.1.1 The system offered communicates in both directions between the mobile operator unit and a fixed basestation by digitally encoded data. Two way wire free communication is achieved between the mobile units and the fixed antennas by digitally encoded infra red. Full duplex communications are provided on all systems between the ship's communication system and the mobile user.
- 1.1.2 The mobile units are small, low weight and battery powered, while the fixed base units employ several infra red antennas located throughout the area covered for communication. The fixed base units interface with analogue signals to the ship's communication system.
- 1.2 The fixed base units can be positioned in virtually any convenient location. Simple to install, the base unit communicates via two twisted pair balanced line circuits which comply with the industry standard RS 422. One pair is used for the transmit signal while the other pair is used for the received signal.
- 1.2.1 Each fixed basestation contains the power supply for up to a maximum of 24 antennas. The actual maximum number of antennas may be reduced by long power cable runs and due allowance for losses must be taken into account. This is a power limitation and further antenna can be connected up to the maximum if auxiliary power supplies are used.
- 1.2.2 Auxiliary power supplies, which are housed in identical enclosures, allow the connection of a further maximum of 24 antennas for each auxiliary supply. The number of antenna may be reduced by long power cable runs.
- 1.2.3 Antennas are connected with a bus topology to the data cable and power cable from the basestation or auxiliary power supply unit.

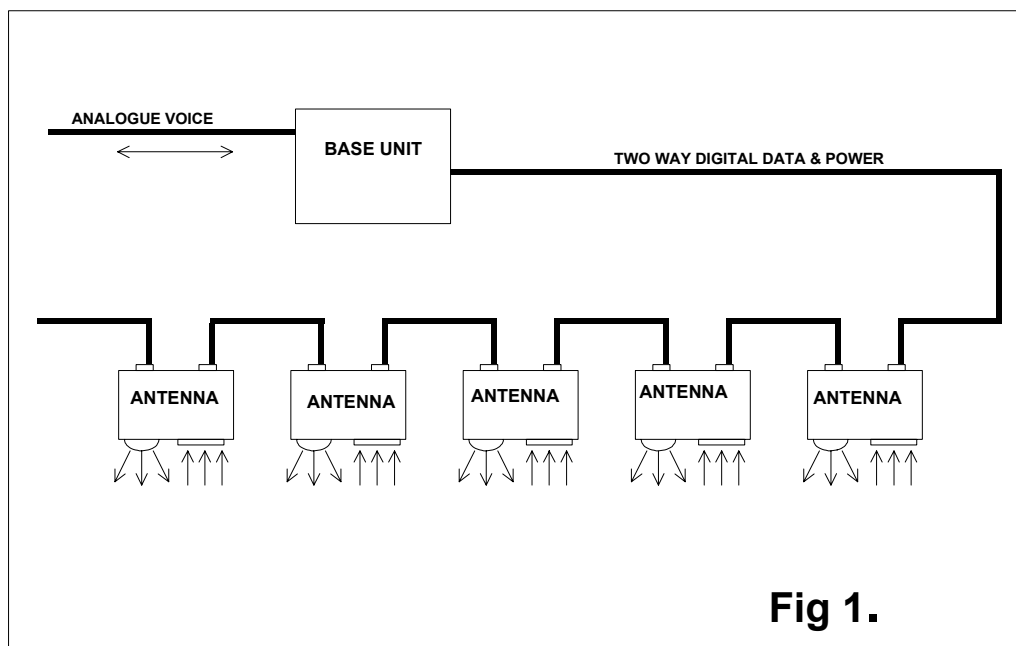

- 1.2.4 Each antenna receives digital data on the RS422 bus and transmits this data in the form of digitally encoded infra red. The infra red data is received by the mobile unit. The encoded infra red from the mobile unit is received by an antenna which converts the infra red signal to an electrical signal before transmitting the data back to the base station on the RS422 bus.
- 1.3 The mobile equipment consists of two units which are:
- a) The integrated headset, and infra red transceiver.
 - b) The waist belt mounted battery pack which provides the operator interface controls. The two units being connected by electrical cord which can be disconnected at the battery pack by a multi-pole connector.
- 1.4 The battery charger which charges up to 6 battery packs simultaneously can be either desk or wall mounted.
- 1.5 To remove the system dependency on the availability of the ship's 24vdc an auto change over power supply can be provided. This unit is supplied by both 24vdc and 230vac. The auto change over power supply unit (ACOPUS) will draw power from either source and supply dc power to the system.
- 1.6 The systems are available with various functional options. The following list gives an outline of some of the features available:
- a) Single channel Baseline, a system with only one channel with the mobile receiving the same speech in both ears.
 - b) Single channel Enhanced, this has the same features as above but different voice channels can be heard in each ear. The mobile user can select to reply to either channel.
 - c) Multi-channel Baseline, a system with only up to 8 channel with the mobile receiving the same speech in both ears.
 - d) Multi-channel Enhanced, this has the same features as above b) but up to 8 different full channels can be received.

2. INTERFACING

- 2.1 The base station interfaces with the ship's communication system and 24 volts dc and or 230/110 volts ac electrical power supply. The ac supply option is available with the addition of the auto change over power supply unit.
 - 2.1.1 The basestation has the following visual indications on the front panel:
 - a) Power on.
 - b) Base transmitting.
 - c) Mobile transmitting.
 - d) External selected.
 - 2.1.2 Audio interfaces to the ship will be at 775mV balanced line with a termination impedance of 600Ω. Other input and output levels can be individually selected at the basestation. All signals are galvanically isolated from earth. Each audio interface consists of an independent 2 wire transmit pair and an independent 2 wire receive pair. In addition when the mobile operator presses the "press to speak" button, clean contacts are made/broken in the basestation to allow the "keying" of other equipment.
 - a) Single channel baseline systems have only one audio interface (4 wire).
 - b) Single channel enhanced systems have two audio interfaces (4 wire).
 - c) Multi-channel systems can be either baseline or enhanced with either one or two audio interfaces per channel. Multi-channel systems also have individual keying contacts.
 - d) The POTS telephone interface unit provides the connection of a single telephone line. This option utilises the external channel of the basestation while the internal channel is still available for direct connection to the ship's communication system.
- 2.2 Mobile to mobile communications are made through the basestation and antenna system. These two way, full duplex communications do not require connections to be made to the analogue interfaces.
- 2.3 Battery chargers require 230/115 volts single phase (to be defined at the time of ordering).
- 2.4 Speech bandwidth of 300 to 3400Hz, with coding similar to the recommendations of CCITT.
- 2.5 The ACOPUSU requires 230vac and 24 vdc.

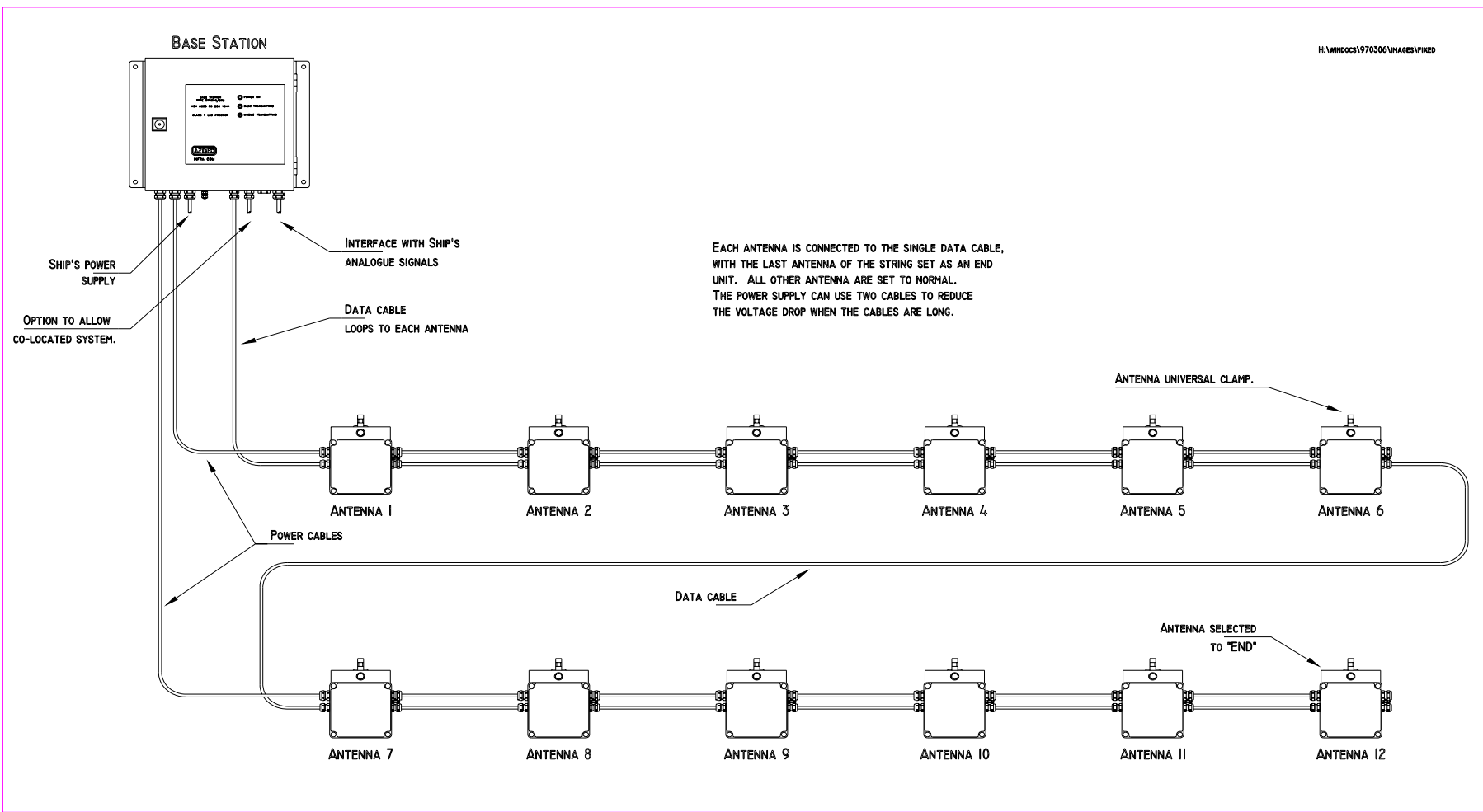

3. DOCUMENTATION

- 3.1 The following documentation will normally be provided as part of the Contract of Supply:
- a) General Views. This document provides details on dimensions, fixing centres and cable termination points of all the supplied equipment.
 - b) Installation Guide.
 - c) Setting to Work Instructions.
 - d) User Guide.
 - e) Cable Jointing Instructions.
- 3.2 Adequate information will be provided, in the above, for the identification and rectification of system defects or malfunctions.
- 3.3 None of the above standard documents are installation or system specific. Documentation will be appropriate for the systems as delivered.

4. DETAILED SPECIFICATION

4.1 Basestation

4.1.1 Physical dimensions:

- a) Height: 30cm.
- b) Width: 30cm.
- c) Depth: 18.5cm
(Cable entry locations at the bottom are not included in the above dimensions.)
- d) Weight: less than 10kg.

4.1.2 Electrical power requirements.

- a) Input voltage range: 18 to 36 volts d.c.
- b) Input power requirements: 200 watts, maximum.
- c) The supply must be fused at 20 Amps.

The defined maximum power requirements assumes the worst case situation, with the minimum voltage from the ship's supply, the maximum number of antennas with the longest power cable lengths.

Note: A typical installation with 6 antennas, short cable runs and the ship's supply being near to the nominal 24 volts would draw a current of less than 3 amps.

4.1.3 Cooling is naturally air cooled, with a maximum of 50 watts of wild heat.

4.1.4 Operating temperature range: 1 to 55°C, relative humidity 30 - 93%. Operational category A to NES 1004, 1995, Data Sheet 9. (Extended temperature range available to 65°C on request.)

4.1.5 Storage temperature range: -10° to +70°C, relative humidity less than 75%. Storage category E to NES 1004, 1995, Data Sheet 9.

4.1.6 Protection rating to IP65.

4.2 Auxiliary Power Supply

4.2.1 Physical dimensions:

- a) Height: 30cm.
- b) Width: 30cm.
- c) Depth: 18.5cm
(Cable entry locations at the bottom are not included in the above dimensions.)
- d) Weight: less than 10kg.

4.2.2 Electrical power requirements of ACOPUSU.

- a) DC Input voltage range: 18 to 36 volts d.c.
- b) Input power requirements: 200 watts, maximum. (See note in 4.1.2.)
- c) The supply must be fused at 20 Amps.

- 4.2.3 Cooling is naturally air cooled, with 50 watts maximum of wild heat.
- 4.2.4 Operating temperature range: 1 to 55°C, relative humidity 30 - 93%. Operational category A to NES 1004, 1995, Data Sheet 9. (Extended temperature range available to 65°C on request.)
- 4.2.5
- 4.2.6 Storage temperature range: -10° to +70°C, relative humidity less than 75%. Storage category E to NES 1004, 1995, Data Sheet 9.
- 4.2.7 Protection rating to IP65.

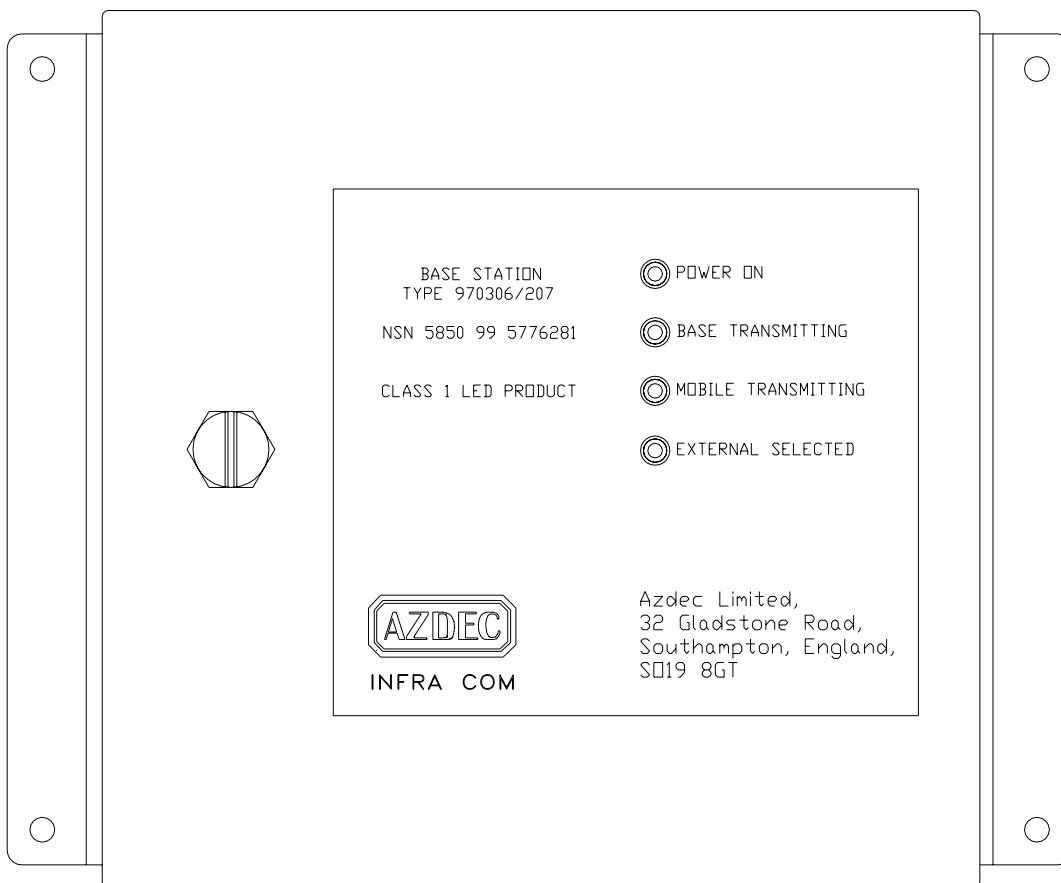

4.3 Infra Red Antenna

4.3.1 Physical dimensions:

- a) Height: 12.5cm.
 - b) Width: 12.5 cm.
 - c) Depth: 14.0cm.
- (The above dimensions exclude the universal mounting bracket and cable glands.)
- d) Weight: less than 2kg.

4.3.2 Electrical power requirements:

Powered direct from basestation or auxiliary power unit at 48 vdc. Power requirements are 4 to 5 watts.

4.3.3 Mounting height typically 2.1 metres. This mounting height gives the following horizontal polar diagram of the limit of two way communications for indoor installations.

4.3.4 Communications media of very high frequency (i.e. IR) can be adversely affected by local conditions of very bright sunlight. When the infra red system is employed for outdoor use the range can be reduced by the sun and extremes of weather. The outdoor antenna and mobile are fitted with alternative electronics and are provided with protection from the sun by sun shades and sun hoods. Bright sun falling directly onto the face of the antenna can reduce the range to approximately half of the performance indoors. Careful design of the locations of the antenna can mitigate this effect. When the system is to be employed in full sunlight, and to allow for the worst possible situation with only one antenna employed, the scale of the polar diagram below should be reduced to half. (See broken line). This allows for the unlikely even of the sun falling directly on the sensitive face and this effect can be virtually eliminated by the use of more than one antenna placed at right angles.

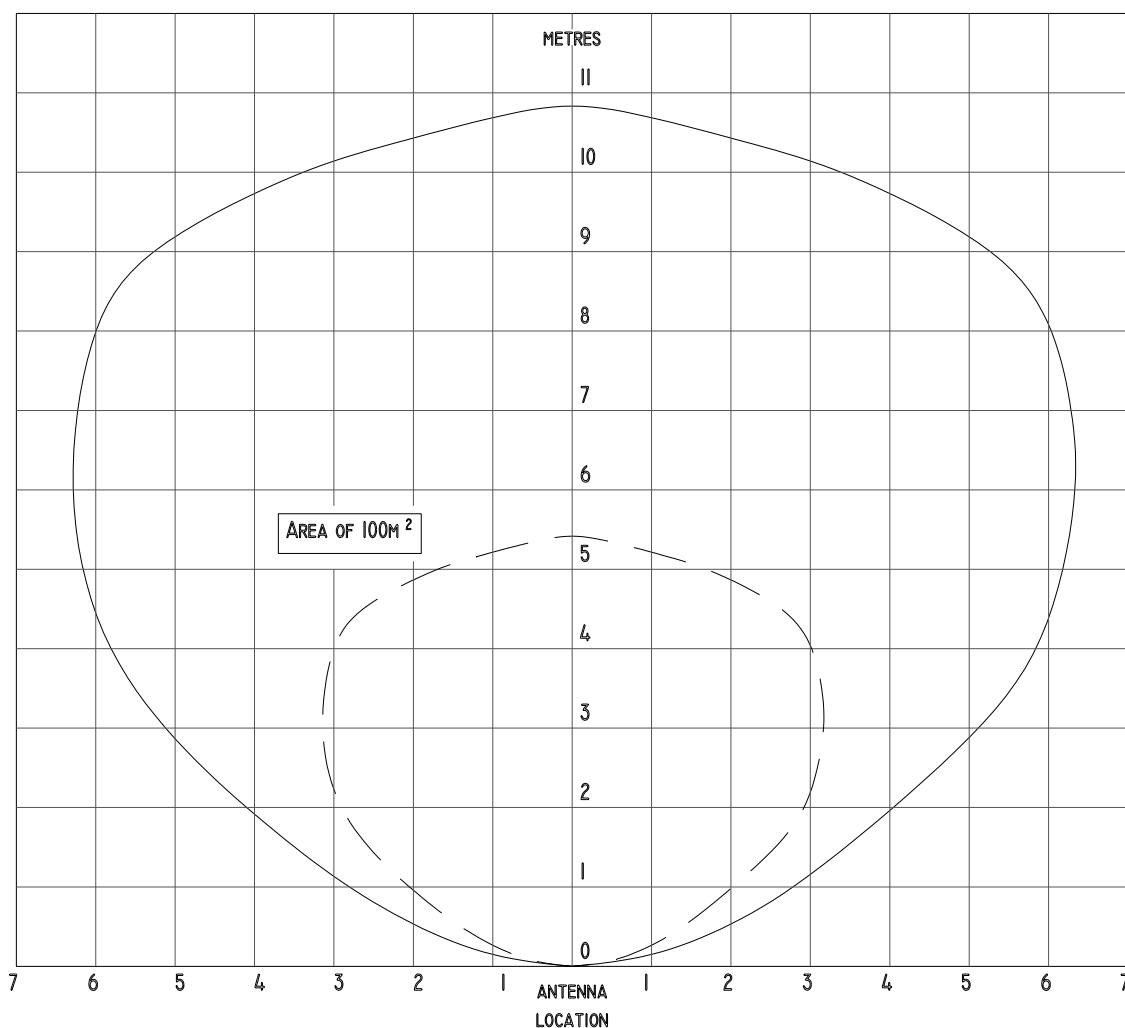

HORIZONTAL POLAR PLOT OF A SINGLE ANTENNA SHOWING
MAXIMUM LIMIT OF TWO WAY COMMUNICATION

- 4.3.5 Cooling is naturally air cooled, with 4 watts maximum of wild heat.
- 4.3.6 Operating temperature range: 1 to 55°C, relative humidity 30 - 93%. Operational category A to NES 1004, 1995, Data Sheet 9. (Extended temperature range available to 65°C on request.)
- 4.3.7 Storage temperature range: -10° to +70°C, relative humidity less than 75%. Storage category E to NES 1004, 1995, Data Sheet 9.
- 4.3.8 Protection rating to IP 66.

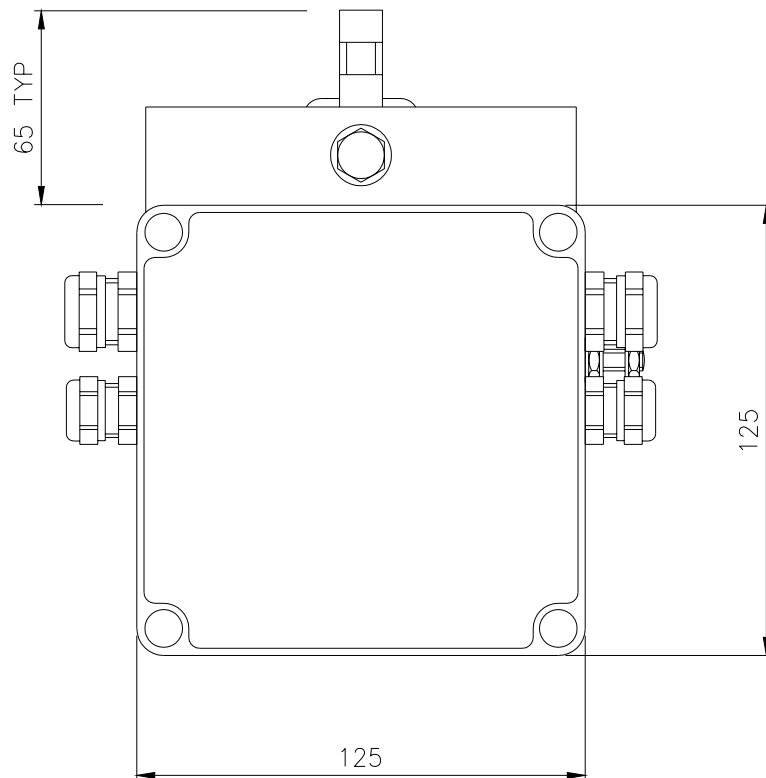

4.4 Auto Change Over Power Supply.

4.4.1 Physical dimensions:

- a) Height: 50cm.
 - b) Width: 47cm.
 - d) Depth: 12.5
- (Cable entry locations at the bottom are not included in the above dimensions.)
- e) Weight: nominally 23kg.

4.4.2 Power requirements:

- a) DC Input voltage range: 18 to 30 volts d.c.
- b) AC input voltage range 230vac \pm 10%
- c) Input power requirements: 600 watts, maximum.

- d) The 24vdc supply must be fused at 20 Amps.
- e) The 230vac must be fused at 10 Amps. Motor rated fuses should be used.

- 4.4.3 Cooling is naturally air cooled, with a maximum of 300 watts of wild heat.
- 4.4.4 Operating temperature range: 1 to 55°C, relative humidity 30 - 93%. Operational category A to NES 1004, 1995, Data Sheet 9. (Extended temperature range available to 65°C on request.)
- 4.4.5 Storage temperature range: -10° to +70°C, relative humidity less than 75%. Storage category E to NES 1004, 1995, Data Sheet 9.
- 4.4.6 Protection rating to IP65.

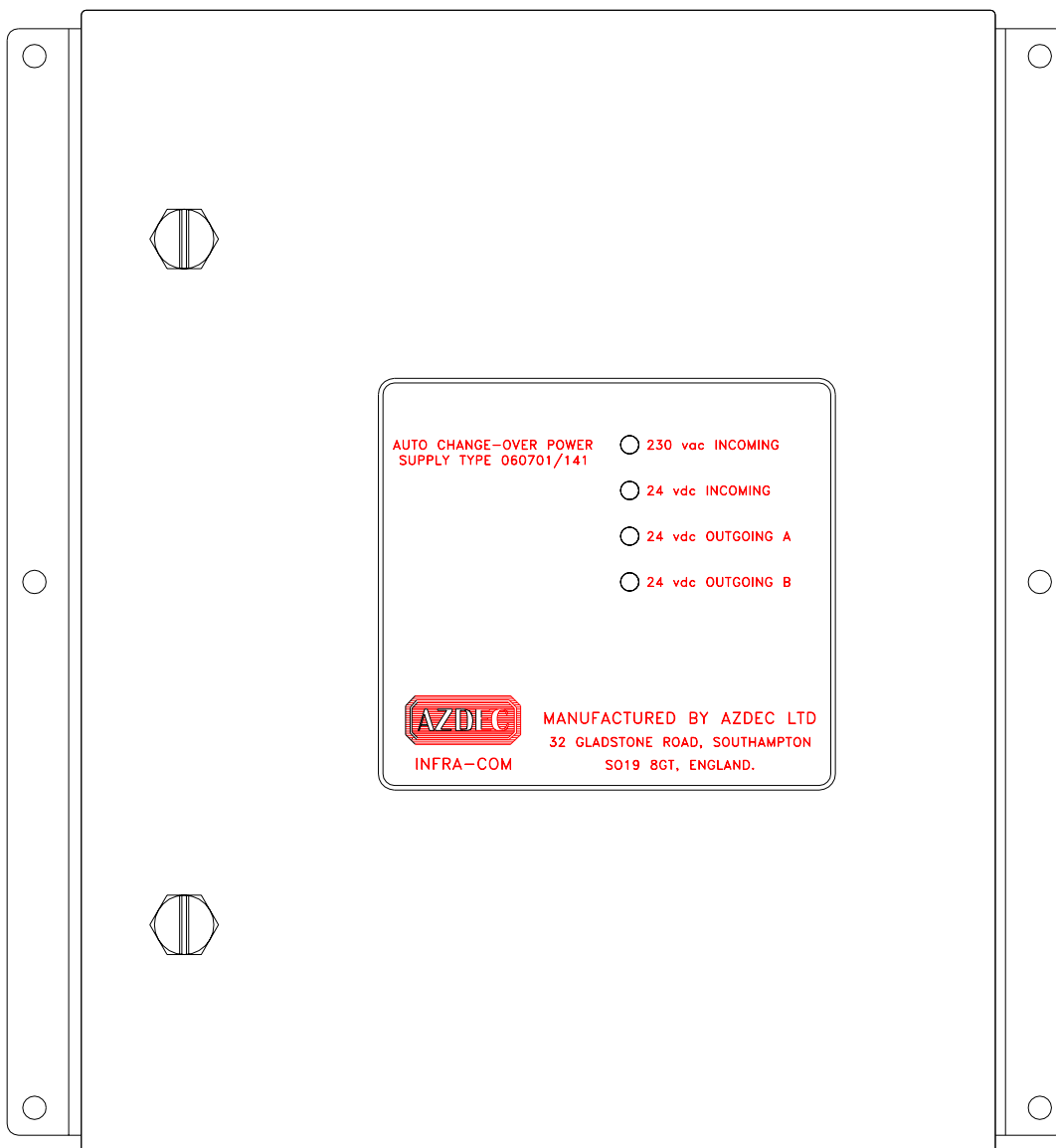

4.5 Mobile Unit

4.5.1 The integrated infra red communications unit and the noise attenuating headset has a nominal weight of 650 grms., the characteristic of which has been tested to BS EN 24869-1. The bridge system is provided with a single sided headset with a weight of less than 600 grams.

4.6 Battery Pack:

4.6.1 Physical Dimensions

- a) Height: 17.5cm.
- b) Width: 10.5cm.
- c) Depth: 3.5cm.
(The width dimension excludes the operator interface controls, the depth in nominal.)
- d) Weight: 500grms

4.6.2 A quick release plug and socket arrangement allows the rapid disconnection of the battery pack and the replacement of a discharged battery with a re-charged unit in a short period of time.

4.6.3 The battery pack is provided with the following operator interfaces:

- A press to speak button.
- On / Off.
- Volume switch.
- Channel selector switch.
- Internal and external selector (enhanced only).
- Visual indication of being switched on.
- Telephone keypad.

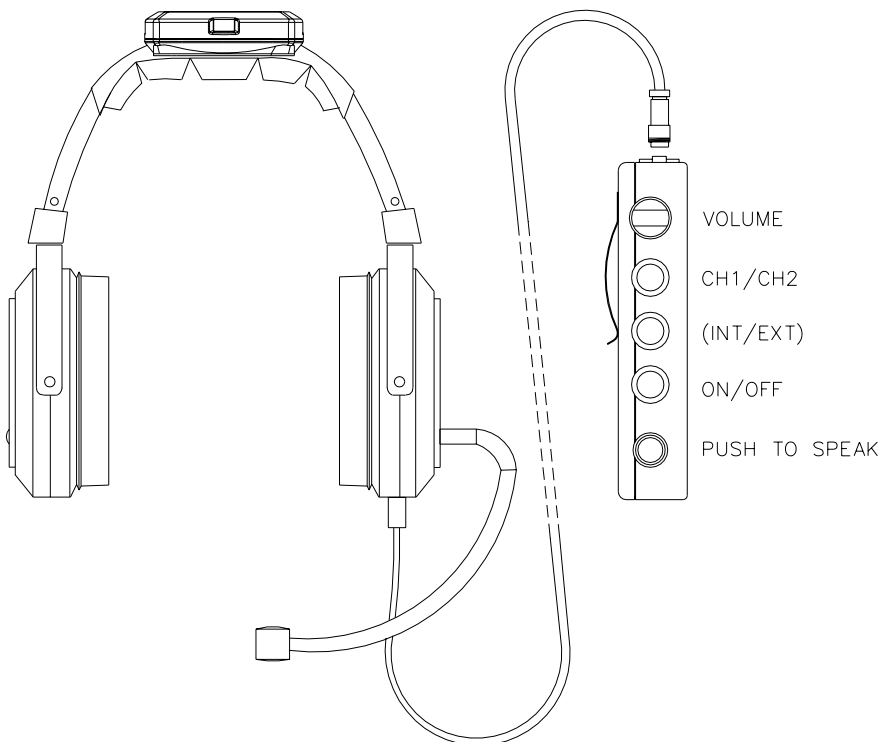

4.7 Battery Charger

4.7.1 Physical Dimensions

- d) Height: 17.0cm.
- e) Width: 54.0cm
- f) Depth: 29.0cm.
- g) Weight: less than 5kg.

4.7.2 Electrical Power Requirements:

230 or 110Vac, 50/60Hz single phase fused externally at 5 amps.

4.7.3 Cooling is natural air cooled with wild heat of 100 watts maximum.

4.7.4 The battery charger can individually supervise, condition and charge 6 battery packs simultaneously.

4.7.5 The battery charger ensures that cells are fully discharged before starting to recharge a battery pack. A complete discharge and recharge cycle is completed in less than 4 hours.

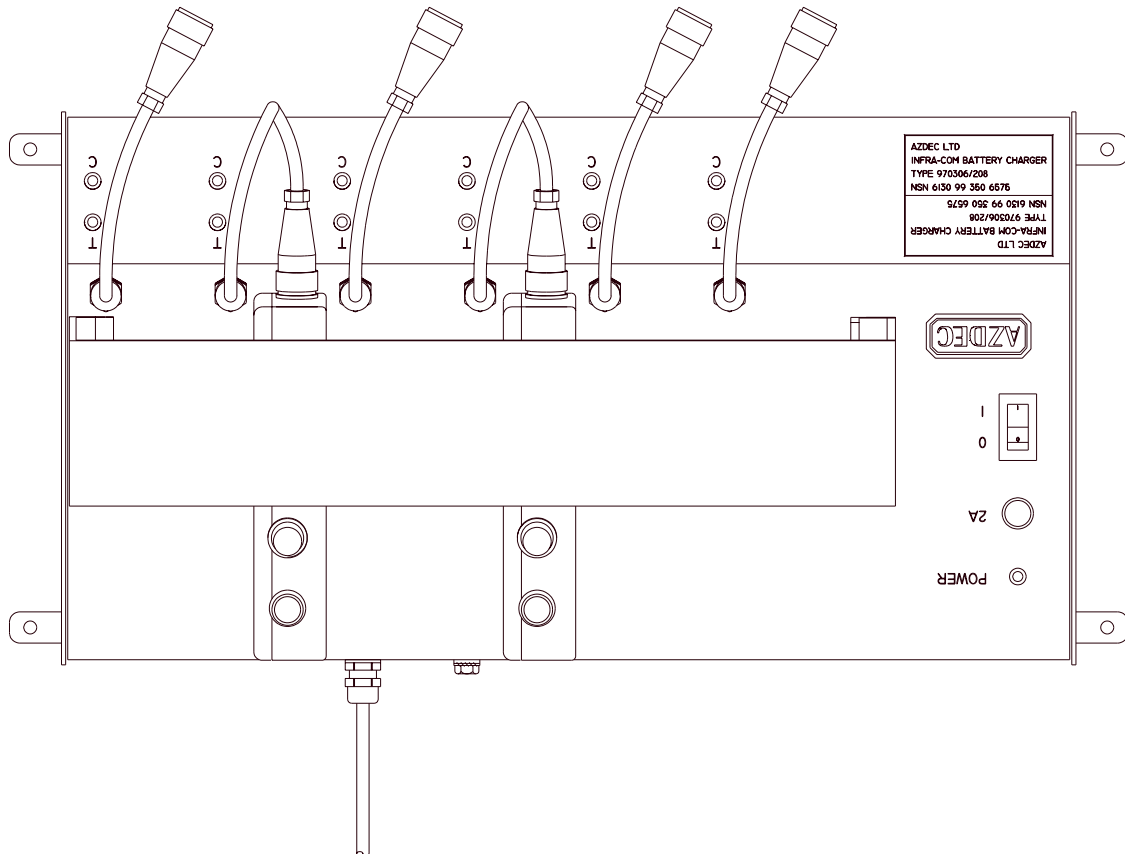

4.8 Ocular Hazard

4.8.1 The Azdec Infra-Com system has been assessed to EN 60825-1 1994 with amendments 1 and 2. As the system is within the Class 1 AEL, nominal ocular hazard distances have not been established.

4.9 Cable Lengths.

4.9.1 The maximum data cable length is 1km, each antenna reduces the maximum cable length by 11 metres. (i.e. 24 antennas, maximum cable length 800 metres.)

4.9.2 Power supply cables must have the voltage drops calculated and cannot exceed a length of 1km.

4.10 EMC Testing

4.10.1 The equipment has been tested as appropriate to Def Stan 59-41 and Mil Std 461D by an independent accredited test house.

4.10.2 Summary of Test Schedule

Def Stan 59-41

Test Ref.	Test Description	Parameters	Supplement
DCE01	Conducted emission on primary power lines	20 Hz - 100 MHz	A
DCE02	Conducted emission on control, signal and power lines	20 Hz - 100 MHz	B
DCE03	Exported Transients, power lines		C
DRE01	Radiated emissions, E field	14 kHz - 1 GHz	D
DRE02	H field radiation	20 Hz - 50 kHz	E
DCS01	Conducted susceptibility, primary power lines	20 Hz - 50 kHz	G
DCS02	Conducted susceptibility, power, control and signal lines	50 kHz - 400 MHz	H
DCS03	Conducted susceptibility, control and signal lines	20 Hz - 50 kHz	J
DCS05	Externally generated transients	(Land and Sea systems)	L
DRS01	H field susceptibility	20 Hz - 50 kHz	U
DRS02	E field susceptibility	14 kHz - 1 GHz	V
DMFS01	Magnetostatic field susceptibility		W

Mil Std 461D

Clause	Test Applied To:	Frequency / Application
CE 101	Primary Power Leads	30 Hz to 10 KHz Ships: AC Leads only Submarines: AC and DC Leads
CE 102	Primary Power Leads	10 KHz to 10 MHz AC and DC Leads
CS 101	Primary Power Leads	DC Leads: 30 Hz to 50 kHz AC Leads: 2 nd Harmonic to 50KHz
CS 114	Power, Control & Signal Lines	10 KHz to 2 MHz 2 MHz to 200 MHz
CS 116	Power, Control & Signal Lines	10 KHz to 100 MHz Damped Sinusoidal Transients

RE 101	EUT & Cables	30 Hz to 100 KHz
RE 102	EUT & Cables	10 KHz to 1 GHz
RS 101	EUT & Cables	30 Hz to 100 KHz
RS 103	EUT & Cables	2 MHz to 18GHz

4.11 Temperature and Humidity

The Infra-Com™ System fixed items meet the operational and storage requirements identified in NES 1004 1995 Data Sheet 9. The appropriate categories are:

Operational Category A
Storage Category E

The following table summarises the tests based on NES 1004 1995 Data Sheet 9.

Operational	Design Requirement		Test Requirement		Duration	Def Stan 00-35 Part 3 Chapter
	Temp °C	Relative Humidity %RH	Temp °C	Relative Humidity %RH		
Operational Category A	1-55	30-93	55 *	30*	16hr	3-01
			55	93	2 days	3-07
			1 *	-*	16hr	3-04
Storage Category E	-10 to 70	< 75	-10	-	16hr	3-04
			70	75	16hr	3-01

* These test are not strictly necessary as per NES 1004 November 1995 Data Sheet 9.

4.12 Shock

The Infra-Com™ System fixed items meet the Shock requirements identified in NES 1004 1995 Data Sheet 27.

4.12.1 Test Method

The equipment shall be securely mounted to the deck of the shock machine and set in an operational condition. The units shall be subjected to a three shots in each orthogonal plane, the first two shots at a level of 210m/s² and the third at 300m/s².

4.13 Vibration

The Infra-Com™ System fixed items meet the Vibration requirements identified in NES 1004 1995 Data Sheet 25. The equipment was checked for functionality both before and after each test category.

4.13.1 Mounting Method

Each unit shall be securely mounted to the bed of the vibration machine by means of its normal fixing points, where available and which will be identified to the test house prior to the commencement of testing.

4.13.2 Severity of Test Category

These test categories are taken from NES 1004 and do not imply that the equipment is designed to work in all regions of the ships.

The Type of Ship shall be:

- a) Surface Ships Minesweeper and Above
- b) Nuclear and Conventional Submarines

The region of use shall be:

- a) Surface Ships Minesweeper and Above:
Main Upper Deck, Protected Compartments, Hull but not Masthead.

- a) Nuclear and Conventional Submarines:
All regions.

4.13.3 Vibration Response

Standard Test Level Peak Values and Frequency Range	Test Condition
0.125 mm frequency range 5 to 33 Hz	Sweep at no greater than 1 octave/min

The equipment shall be subject to the limits defined above in 3 mutually perpendicular axes. The initial amplitude should normally be half that specified to avoid equipment damage.

Any resonances with a Q of greater than 3 should be noted.

4.13.4 Endurance

Reference: Def Stan 00-35 (Part 3) Chapter 2-01 Test M1 Clause 2

The equipment shall be tested in the most unfavourable direction identified in section 4.12.3. The duration of the test shall be equally divided between the operating conditions of the equipment including the "off" condition.

Peak Amplitude	Frequency	Duration
0.125 mm	33 Hz	A total of 3 hours.
0.125 mm	At resonant frequencies noted in section 4.12.3	

4.14 Air Pressure

The Infra-Com™ System fixed equipment meet the operational and storage requirements identified in NES 1004 1995 Data Sheet 13 and 14. The following section identifies a set of tests which encompasses the extremes of all of the applicable tests.

The equipment shall be checked for functionality both before and after each test category.

4.14.1 Summary Tests

4.14.1.1 Pressure Above Atmosphere

Temperature as defined in Def Stan 07-55 (Part 2) Section 2/1 Test B15 Clause 3b.
Pressure 80 mb above Standard Atmosphere.

4.14.1.2 Air Pressure Variation

Def Stan 07-55 (Part 2) Section 2/1 Test B15 Clause 4 for a pressure of 1314 mb at temperature of $20 \pm 5^\circ\text{C}$. Duration of 1 hour.

Def Stan 07-55 (Part 2) Section 2/1 Test B11 Clause 4 for a pressure of 712 mb at temperature of $20 \pm 5^\circ\text{C}$. Duration of 1 hour.

Def Stan 07-55 (Part 2) Section 2/1 Test B15 Clause 2 for high pressure of 872 mb and Test B11, Clause 2a for low pressure of 712 mb. A temperature of $20 \pm 5^\circ\text{C}$ shall be maintained during the test. The duration of the test shall be 50 cycles. The test sequence is defined in:

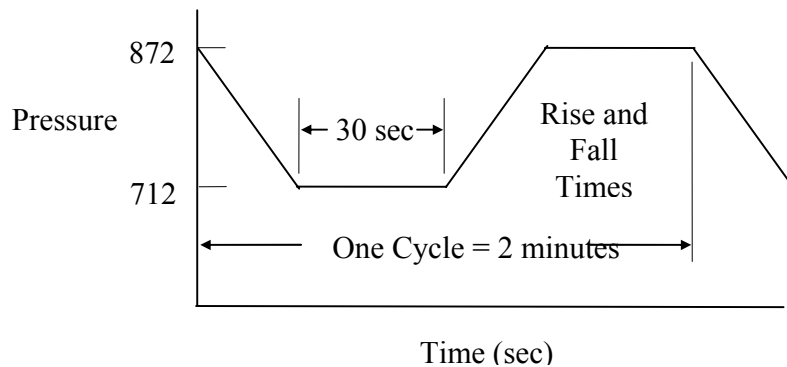

4.15 Failure Rate

4.15.1 The failure rates for each of the system elements are either based on values supplied by the manufacture of the component or on the failure rates for the component type as identified in MIL-HDBK-217F.

4.15.2 Typical systems as installed in a machinery space consisting of 1 Basestation, 12 antennas and 5 mobiles available would, using the method defined in MIL-HDBK-217F, give an MTBF of 30,600 hours for the system.

4.15.3 Detailed Assessment

4.15.3.1 Basestation

The failure rate for the Basestation is as follows:

	Failures in 10⁶ hours
Power Supply	2.40
Main Electronics	24.17

The total failure rate is therefore:

$$2.40 + 24.17 = 26.57 \text{ failures in } 10^6 \text{ hours}$$

This gives a MTBF of 37636 hours.

4.15.3.2 Antenna

The total failure rate is

$$21.82 \text{ failures in } 10^6 \text{ hours.}$$

This gives a MTBF of 45830 hours.

4.15.3.3 Mobile Unit

The total failure rate is

$$21.81 \text{ failures in } 10^6 \text{ hours.}$$

This gives a MTBF of 45851 hours.

4.15.3.4 Battery Charger

The Battery Charger 970306/208 is a 6 channel charger where each channel has its own set of components for charging 1 Battery Pack. The Battery Charger takes its power from a 115 Vac supply via a simple power supply which is common to all 6 charging units.

The battery charger is only deemed to have failed when all 6 channels have failed.

The failure rate for the Battery Charger is as follows:

$$2.6 \text{ failures in } 10^6 \text{ hours.}$$

or MTBF is 384615 hours.

4.15.3.5 Auxiliary Power Supply

The Auxiliary Power Supply has one module the Power Supply.

The failure rate for the Auxiliary Power Supply is as follows:

	Failures in 10⁶ hours
Power Supply	2.40

The total failure rate is therefore

2.40 failures in 10⁶ hours.

This gives a MTBF of 416,667 hours.

4.16 Intrinsic Availability

4.16.1 The intrinsic availability of the system is greater than 99.95% as defined in DEF STAN 00-40, (i.e. the probability at any instance during an operational period of 90 days of the system not being available will be better than 0.9995).

4.17 Downtime

The downtime due to any one preventative maintenance activity, during the operational period will not exceed 5 minutes.

4.18 Noise Attenuation

The noise attenuating headset has a defined noise reduction figure of 21dB.

5. NATO STOCK NUMBER / AZDEC PART NUMBER CROSS REFERENCE

5.1 The following table provides a conversion between Azdec Part Numbers and Nato Stock Numbers.

Azdec Part Number	Description	Nato Stock Number
970306/201	Noise Attenuating Headset & Mobile Unit	5965-99-6239442
970306/202	Lightweight Headset & Mobile Unit	5965-99-8110364
970306/203	Battery Pack - Baseline System	6130-99-5492371
970306/204	Battery Pack - Enhanced System	6130-99-4539042
970306/206	Basestation Baseline System	5850-99-2581044
970306/207	Basestation Enhanced System	5850-99-5776281
970306/208	Battery Charger	6130-99-3506575
970306/209	Antenna - Long Cable	5985-99-5492809
970306/210	Auxiliary Power Supply Unit	6130-99-5174710
970306/211	Enhanced Headset and Mobile Unit	5965-99-5735140
970306/220	Head pad - Noise Attenuating Headset	5965-99-5492812
970306/221	Ear pads - Noise Attenuating Headset	5965-99-5624784
970306/230	Gland Kit (PG9)	5975-99-5642923
970306/231	Gland Kit (PG11)	5975-99-0007264
970306/232	Gland Kit (PG13.5)	5975-99-1513187
970306/043	Basestation to Antenna power cable	6145-99-0962821
970306/045	Basestation to Antenna data cable	6145-99-2775732

Specification correct at date of issue but due to continuous product improvement and development Azdec Ltd reserves the right to change any aspect without notice.